

CONDOR TOUCH-FREE ELECTRONIC LAVATORY FAUCET

PECIFICATIONS

Touch free electronic faucet for deck mounted installations with integrated panel. For cold or premixed water, activated by infrared sensor. Powered by an externally mounted 9V battery or 9V transformer. Latching solenoid valve is located in the IP67 water proof dual power input box. Sensor settings adjustable by optional remote control. Other sensor settings (delay in, delay out and security time) can also be adjusted by remote control. Faucet will automatically shut off after being used for more than 90 seconds. Sensor features a low battery level indicator.

OPERATION

Touch free electronic faucet. The faucet is activated automatically when the users brings their hands within the sensor range, and stops when the users remove their hands.

APPLICATION

Deck mounted faucet combining an elegant design with

anti-vandal features. The faucet includes a dual power input box that can be used to operate the product by battery or transformer. When used with a transformer it has an integrated automatic battery backup. Includes an integrated panel to cover remaining holes on the deck surface. Helps washrooms to stay cleaner and to save water. Prevents cross contamination. Ideal for stadium, train and bus stations & highway rest stops.

BENEFITS

- Easy Retrofit installation – integrated panel
- Flexibility in choosing a power source – IP67 water proof dual power input box that operates with a battery or a transformer
- Automatic battery backup when used with a transformer
- Comes with an advanced SSR aerator with flow restriction and adjustable water stream angle for splashing prevention
- All sensor settings adjustable on-site by means of remote control

PRODUCT AT A GLANCE

Installation	Deck mounted
Power Supply	• 9V battery • 9V transformer **When used with a transformer: optional 9 V Lithium battery for back-up in case of power failure.
Operating pressure	0.5-8.0 bar / 7.0-116.0 PSI For greater water pressure please use a pressure reducing valve
Water supply	Cold or premixed water
Water flow	6 LPM / 1.58 GPM - SSR PCA stream
Water Saving Options	4 LPM / 1 GPM ; 3 LPM / 0.8 GPM 1.89 LPM / 0.5 GPM ; 1.3 LPM 0.35 GPM - PCA spray
Water temperature	70°C Maximum

FLOW RATE vs PRESSURE

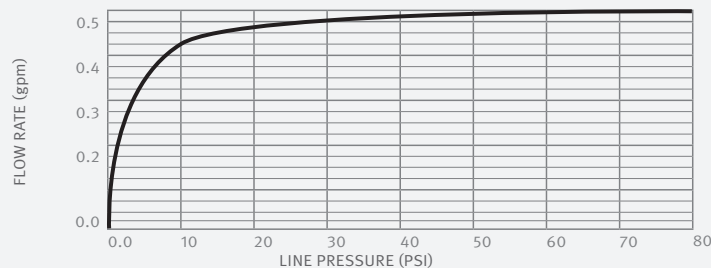

This graph applies to 0.5 GPM option only.

ORDERING INFORMATION

MODEL	CODE	POWER
Condor	210000	9V battery
Condor E	210200	9V transformer

OPTIONS

OPTION	CODE
Remote control	07100005

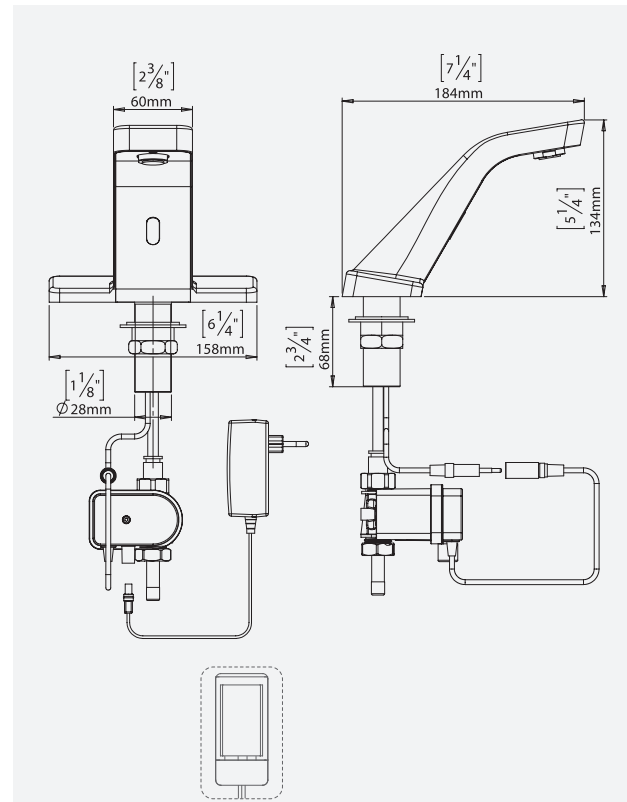

ADVANTAGES



LEED RATING



OPTIONAL HYGIENE FLUSH



ROBUST BRASS BODY



ADJUSTABLE SETTINGS



EASY TO INSTALL

APPROVALS



ADA DESIGNED



UPC



COMPLIES TO ASME A112.18.1 / CSA B125.1

777 Passaic Avenue
Clifton NJ, 07012
USA: sternusa@sternfaucets.com
International: info@sternfaucets.com
Toll Free: 1-800-4364410

www.sternfaucets.com