

# BEHIND THE MIRROR FOAM SOAP DISPENSER

## SPECIFICATIONS

Touch-free electronic foam dispenser for concealed installation behind the mirror. Activated by infrared sensor. Chrome plated spout. Includes a 1 liter soap bottle and bottle support. To be used with non-proprietary soap for maximum savings. Adjustable settings by remote control: Soap dosage, air quantity ("foamability"), soap tank refill, temporary off and reset to factory settings.

## OPERATION

Touch-free electronic foam soap dispenser operated by infrared sensor. The foam dispenser automatically activates when users place their hands within sensor range, providing a measured amount of foam (adjustable by remote control). If the users remove the hand before the full amount is dispensed, the soap dispenser immediately stops the foam flow.

## APPLICATION

The concealed, easy installation behind the washroom mirror offers an elegant, sleek and minimalistic design, ideal for office buildings, hotels and leisure sites, airports and transportation hubs and luxurious commercial locations.



## PRODUCT AT A GLANCE

Installation	Concealed Behind The Mirror
Power Supply	12V transformer
Soap	1 Liter soap bottle The peristaltic pump enables the use of any kind of liquid soap, detergent or antibacterial gel
Viscosity	Up to 100 cPs
Refill	Soap priming by remote control or by an easy-to-use manual refill button

## ORDERING INFORMATION

MODEL	CODE	POWER
BTM FOAM E	280250	12V transformer

## OPTIONS

OPTION	CODE
Remote control for foam SD	07100009

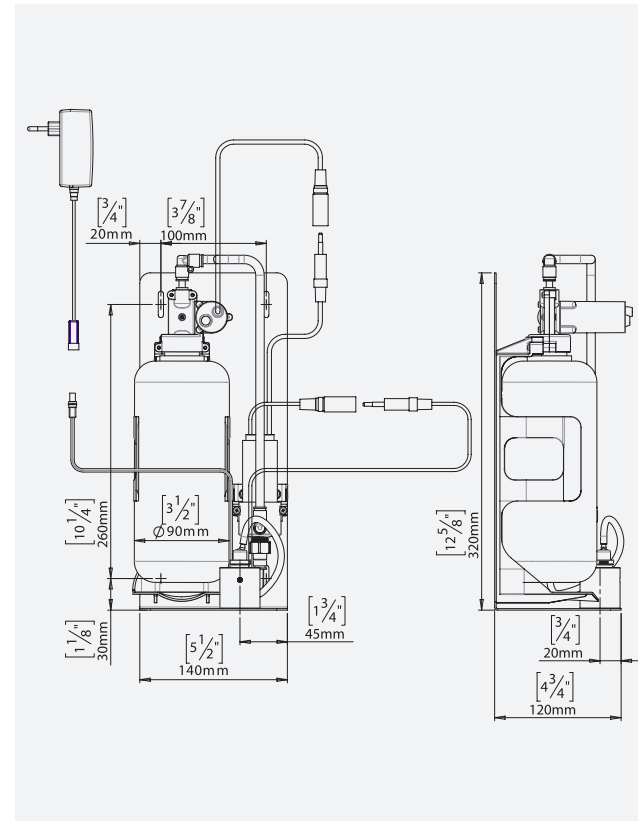

## ADVANTAGES



LEED RATING



SOAP AND WATER



GERM FREE



CHANGE SETTINGS



EASY TO INSTALL



CLOGGING FREE



ADA DESIGNED

777 Passaic Avenue  
Clifton NJ, 07012  
USA: sternusa@sternfaucets.com  
International: info@sternfaucets.com  
Toll Free: 1-800-4364410

www.sternfaucets.com