

D28 DUAL POWER

TOUCH-FREE ELECTRONIC WALL-MOUNTED FAUCET

SPECIFICATIONS

Touch-free wall-mounted electronic faucet. Activated by an infrared sensor. For cold or premixed water. Powered by IP67 dual power input box that allows the faucet to be used with 9V battery or 9V transformer. Can be powered by a 9V transformer and an integrated back up system to be used with 9V lithium battery enabling the faucet to be used normally in case of power failure. Chrome plated body, other finishes available. Adjustable settings by remote control: sensor range, security time, delay in, delay out, on-off and reset to factory settings.

OPERATION

The faucet will automatically activate when users place their hands in the sensor range and will stop once the users remove their hands.

APPLICATION

Wall-mounted faucet. Combines a minimalistic design with vandal resistant features. Helps washrooms stay clean and saves water. Easy installation. Long lasting even in the harshest installation sites. Ideal for shopping malls, sport facilities and entertainment centers.

PRODUCT AT A GLANCE

Installation	Concealed wall-mounted
Power Supply	• 9V battery • 9V transformer with backup system
Operating pressure	0.5-8.0 BAR / 7.0-116.0 PSI
Water supply	Cold or premixed water
Water flow	5 LPM / 1.32 GPM Honeycomb TT Laminar
Water Saving Options	Water saving option: 1.89 LPM / 0.5 GPM PCA spray
Water temperature	70°C Maximum
Security Time	90 seconds. Adjustable by remote control

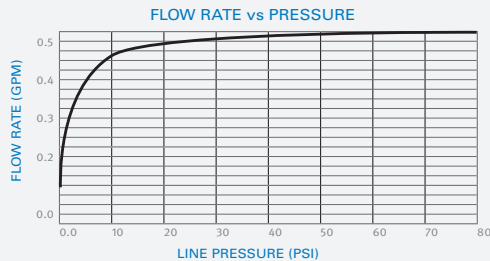

OPTIONS

OPTION	CODE
Remote control	0710005
Matching battery-powered soap dispenser	350920
Matching transformer-powered soap dispenser	350925
Iron frame	500100

ORDERING INFORMATION

MODEL	CODE	POWER	ADDITIONAL SPECIFICATIONS
D28 DUAL POWER B	352300	9V battery	Concealed installation
D28 DUAL POWER E	352400	9V transformer and backup system	
D28 DUAL POWER LE	352410	9V transformer and backup system	Concealed installation Long spout version 273mm/10.75"

This graph applies to 0.5 GPM option only.

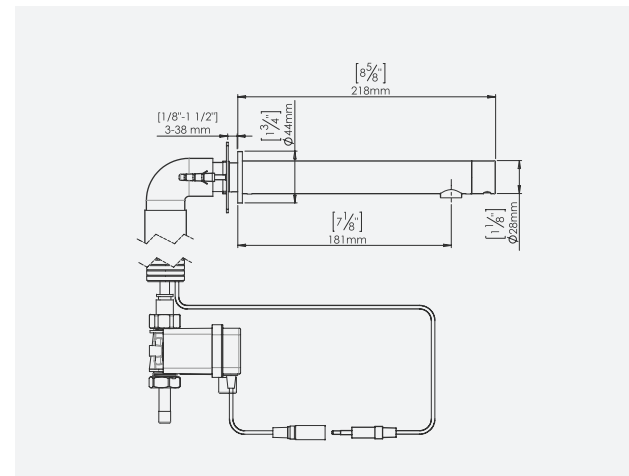
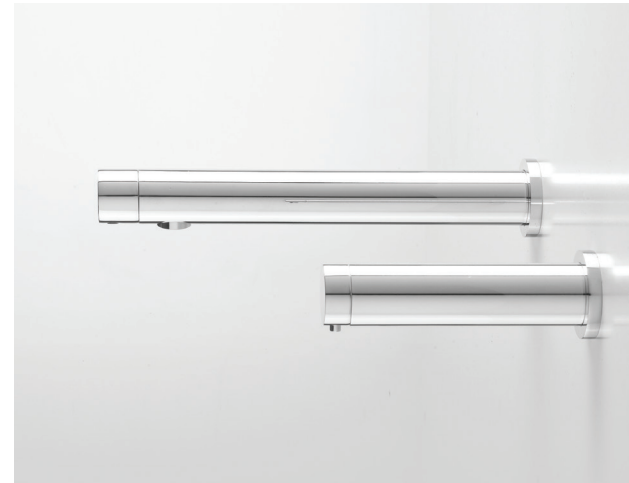

ADVANTAGES



LEED RATING



OPTIONAL HYGIENE FLUSH



SOAP AND WATER



GERM FREE



ADJUSTABLE SETTINGS



EASY TO INSTALL



ADA DESIGNED

APPROVALS



777 Passaic Avenue
Clifton NJ, 07012
USA: sternusa@sternfaucets.com
International: info@sternfaucets.com
Toll Free: 1-800-4364410
www.sternfaucets.com