

# SWAN 1000 TOUCH-FREE ELECTRONIC LAVATORY FAUCET

## SPECIFICATIONS

Touch-free electronic faucet for deck-mounted installations. Activated by infrared sensor. With mixer for water temperature adjustment for hot and cold water. Filters included. Chrome plated body, other finishes available. Battery version includes a low battery indicator. Latching solenoid valve is located above deck inside the product for added vandal protection. Adjustable setting by remote control: sensor range, security time, delay in, delay out, on-off and reset to factory settings. 24 hour mandatory hygiene flush available upon request.

## OPERATION

Touch-free electronic faucet. The faucet is automatically activated when the users place their hands in the sensor range and stops when the users remove their hands.

## APPLICATION

Deck-mounted faucets. Combining an elegant minimalist design with anti-vandal features. Easy installation. Long lasting even in the harshest installation sites. Helps washrooms stay clean and saves water. Prevents cross contamination. Ideal for stadiums, train and bus stations and highway rest stops.

## PRODUCT AT A GLANCE

Installation	Deck-mounted
Power Supply	• 9V battery • 9V transformer
Operating pressure	0.5-8.0 bar / 7.0-116.0 PSI
Water supply	Hot and cold water
Water flow	6 LPM / 1.58 GPM - SSR PCA stream
Water Saving Options	4 LPM / 1 GPM ; 3 LPM / 0.8 GPM 1.89 LPM / 0.5 GPM ; 1.3 LPM 0.35 GPM - PCA spray
Water temperature	70°C Maximum
Security Time	Auto shutoff after 90 seconds. adjustable by remote control

FLOW RATE vs PRESSURE

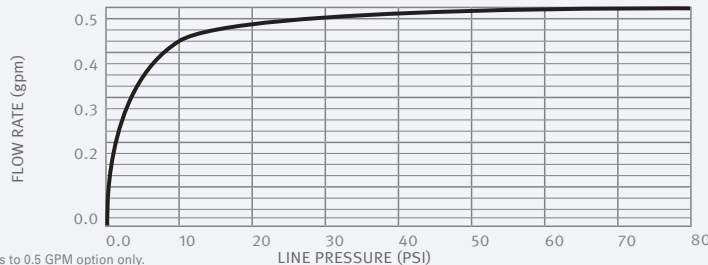

This graph applies to 0.5 GPM option only.

## ORDERING INFORMATION

MODEL	CODE	POWER	ADDITIONAL FEATURES
SWAN 1000	252210	9V internal battery	AB 1953 Lead Free
SWAN 1000 B	252310	9V battery	With mixer for water temperature adjustment
SWAN 1000 E	252420	9V transformer	

## OPTIONS

OPTION	CODE
Remote control	07100005
Matching battery-powered soap dispenser	250920
Matching transformer-powered soap dispenser combination	250910

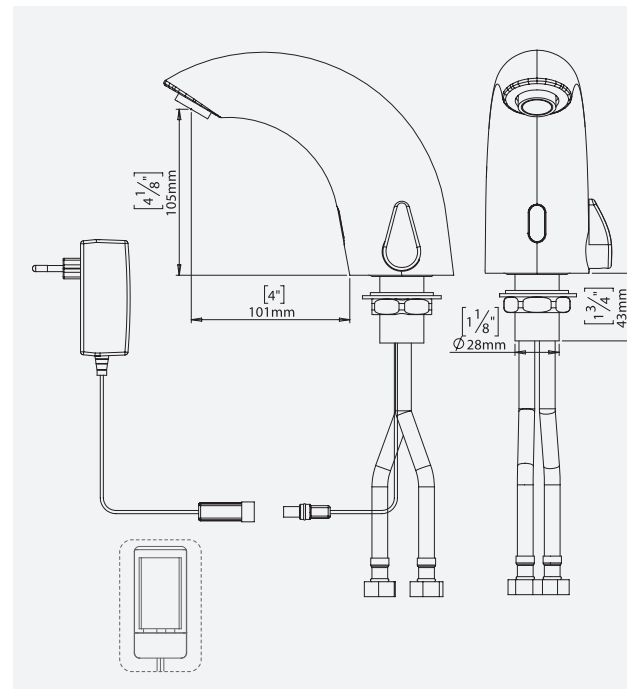

## ADVANTAGES



LEED RATING



OPTIONAL HYGIENE FLUSH



SOAP AND WATER



GERM FREE



ADJUSTABLE SETTINGS



EASY TO INSTALL



ADA DESIGNED

## APPROVALS



777 Passaic Avenue  
Clifton NJ, 07012  
USA: sternusa@sternfaucets.com  
International: info@sternfaucets.com  
Toll Free: 1-800-4364410

www.sternfaucets.com