

INSTALLATION AND MAINTENANCE GUIDE
PERFECT TIME SH 1042 T



stern
STERN ENGINEERING LTD.

INDEX

- 1** TECHNICAL DATA
- 2** PACK CONTENTS
- 3** PRE-INSTALLATION INFO
- 4-6** INSTALLATION
- 7-10** FLOW TIME ADJUSTMENT
- 11-12** MAINTENANCE
- 13-14** BATTERY REPLACEMENT
- 15** SPARE PARTS LIST
- 16** TROUBLE SHOOTING
- 17** WARRANTY

TECHNICAL DATA

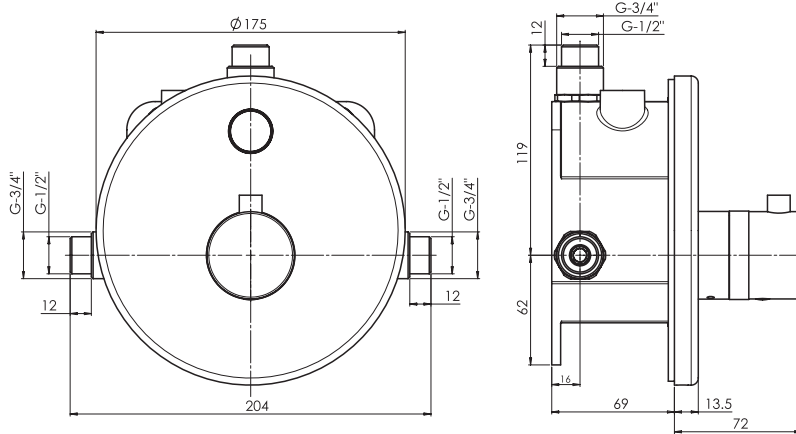

PERFECT TIME SH 1042 T / TE

Product control:	Touch using Piezo technology
Minimum operating water pressure:	1.0 bar
Maximum operating water pressure:	8.0 bar
Max. Hot water supply:	70° C
Power specification:	9V DC or IP68 Transformer (TE Version)
Default flow time:	120 seconds. Adjustable
Programmable flow time:	5 to 2600 seconds
24 hs.hygiene / anti freeze flush:	Optional. Can be enabled or disabled on site.

PACK CONTENTS

Mud Protector

1 x Rosette Assembly

1 x SH 1042 T Box with components

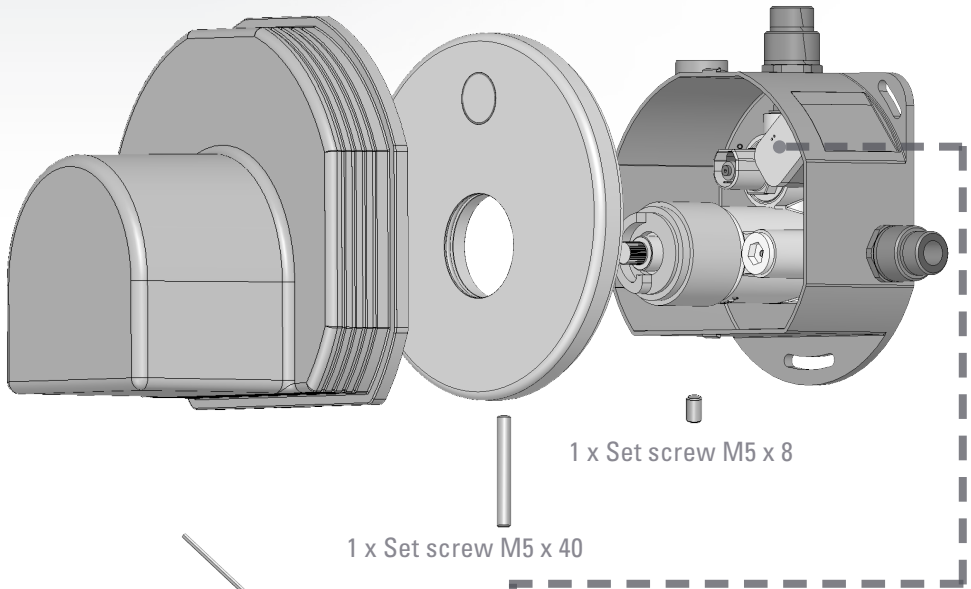

1 x Set screw M5 x 8

1 x Set screw M5 x 40

1 x Allen key 2.5mm

1 x Thermostatic mixing handle

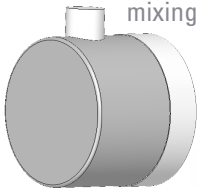

1 x Set screw M5 x 8

1 x Screw Cover

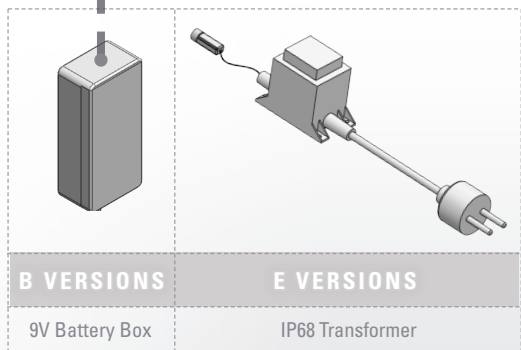

PRE-INSTALLATION INFORMATION

Check contents

Separate all parts from the packaging and check each part with the pack contents section. Pay attention to the different models variations.

Make sure all parts are accounted for before discarding any packaging material.

If any parts are missing, do not attempt to install your electronic faucet until you obtain the missing parts

Preparation for installation

Flush water supply lines thoroughly before installing the faucet. Do not allow dirt, Teflon tape or metal particles to enter the water supply. Shut off water supply.

Important

All plumbing is to be installed in accordance with applicable codes and regulations.

OPERATION

To operate the Perfect Time SH 1042 T / TE controls, simply touch the designated area at the Piezo shower control. Default flow time is 2 minutes. If you do not need more water, just touch the designated area again to stop the shower water flow before the default time has passed.

To change the flow time, proceed to page number 7.

INSTALLATION

1. Shut off the water supply.
2. Cut and adequate opening in the wall for the dimensions of the box.
3. Insert the Perfect Time SH 1042 box through the opening.

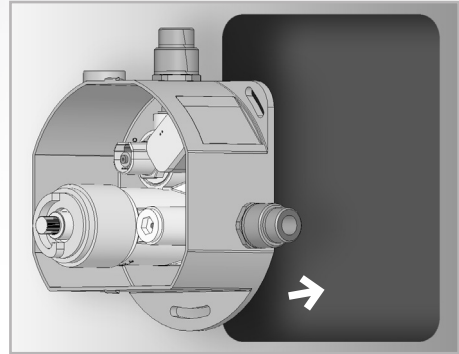

4. Connect the Perfect Time SH 1042 box to the water supply. For your convenience the box include two options to connect $\frac{1}{2}$ " or $\frac{3}{4}$ " to the water supply pipes.

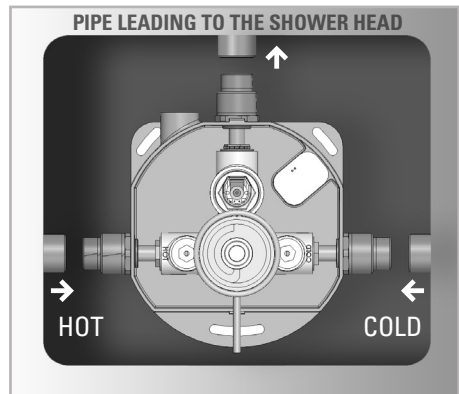

5. Connect the Perfect Time SH 1042 box to the pipe leading to the shower head (not supplied).

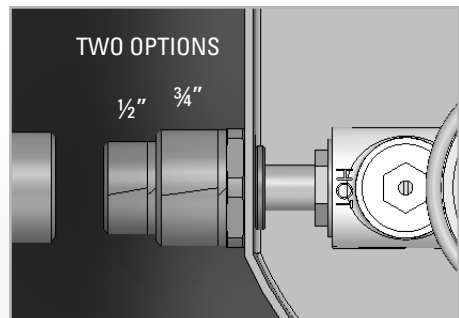

INSTALLATION

6. Turn on the water supply. Make sure there is no water leakage.

7. Assemble the temporary protective cover to protect the Perfect Time SH 1042 box.

Important: Pay attention to the maximum mark marked on the cover, the finish wall line can't go over the maximum mark in the cover.

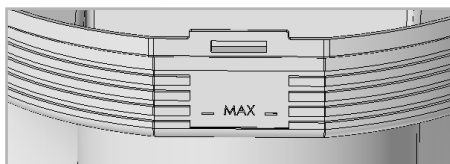
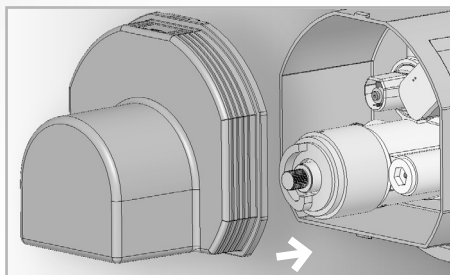

8. Once the works are finished, cut the protective cover box.

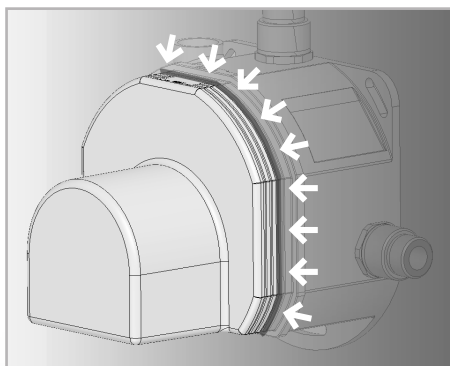

9. Unscrew lightly the screw M5 x 40 located underneath the rosette.



INSTALLATION

10. Connect the connectors as indicated: one to the solenoid valve and the other one to the power supply.

11. Assure that the cables are connected properly.

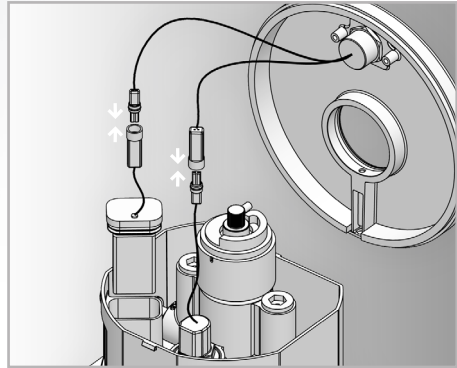

12. Place the rosette in its place and level it that the piezo button is in the top.

13. Secure the screw M5x40.

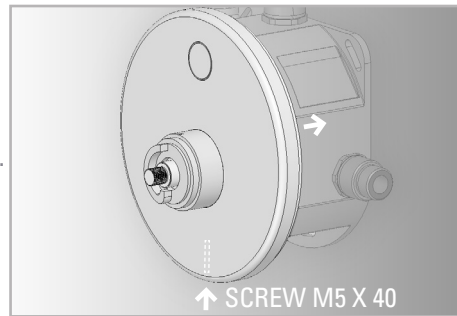

14. Now place the Thermostatic Mixing Handle and tighten it with the screw M5x8.

15. Finally place the screw cover into the Thermostatic Mixing Handle hole.

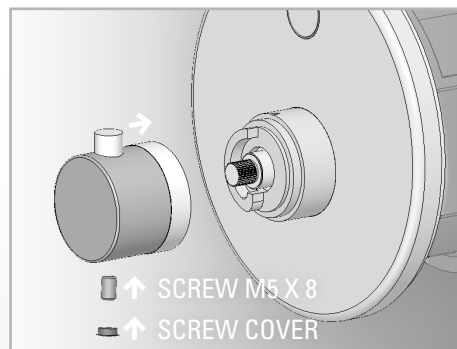

FLOW TIME ADJUSTMENT

Adjustment levels

The flow time is programmable on site. If necessary, the default flow time of 30 seconds can be adjusted to any value between 5 to 2600 seconds. The Perfect Time adjustment mechanism is composed by 3 adjustment levels for changing the flow time. An indicator light (LED) will guide you from one level to the other.

The following table shows the number of steps in each level, the duration at each step and how to recognize in what adjusting level you are.

	Level 1	Level 2	Level 3	Level 4 <small>enables the hygiene flush option when available</small>	Out of adjusting mode
No. of steps	100 steps	100 steps	100 steps		
Seconds to be increased by touching once	1 second	5 seconds	20 seconds		
Adjustment level indicator	After entering into adjusting mode level 1 is reached	Indicator light blinks twice	Indicator light blinks 3 times	Indicator light blinks 4 times	Indicator light blinks 5 times

The following examples show how to manage the adjustment levels:

Example 1: You wish to adjust the flow time to 28 seconds.

At level 1 perform 3 steps of 1 second (you will get 3 seconds). Total: 3 seconds

Go to level 2 and perform 1 step of 5 seconds (you will get 5 seconds). Total: 8 seconds)

Go to level 3 and perform 1 step of 20 seconds (you will get 20 seconds). Total: 28 seconds.

FLOW TIME ADJUSTMENT

Example 2: You wish to adjust the flow time to 45 seconds.

At level 1 do not perform any step and wait until you reach level 2 (you will get 0 seconds). Total: 0 seconds

At level 2 perform 1 step of 5 seconds (you will get 5 seconds). Total: 5 seconds)

Go to level 3 and perform 2 steps of 20 seconds (you will get 40 seconds). Total: 45 seconds.

Example 3: You wish to adjust the flow time to 60 seconds.

Do not perform any step at levels 1 and 2 and wait until you reach level 3 (you will get 0 seconds). Total: 0 seconds

At level 3 and perform 3 steps of 20 seconds (you will get 60 seconds). Total: 60 seconds.

FLOW TIME ADJUSTMENT

How to adjust the flow time

1. Shut off the water supply
2. Take off the screw cover located on the bottom of the Thermostatic Mixing Handle.
3. Unscrew screw M5x8 and M5x40 using the 2.5mm Allen key.
 - a. Remove the thermostatic mixing handle and the rosette to have access to the piezo.
4. Disconnect the power supply (batteries or transformer).
5. Wait ten seconds
6. Reconnect the power supply.
7. The indicator light (LED) on the back of the piezo button will start blinking. After a few blinks the LED will give a steady red light. Touch the designated area at the Piezo button when the steady red light is still on to enter into adjusting mode. When done correctly, the light will stop blinking.

Note: If you will not press at the indicated area, the previous adjustment will remain.

8. By touching the Piezo button the new flow time will be programmed. In adjusting mode level 1, each touch increases the flow time by 1 second with a maximum of 100 seconds. You will see the LED blinking every time that a new step is performed.
9. If you have reached your desired flow time at this level, stop pressing the Piezo button. The LED will blink 2 times, 3 times, 4 times and after the 5th time you will leave the adjusting mode. The Perfect Time is now adjusted to the desired flow time.
10. If you need to perform steps at the adjusting level 2, wait after you see the indicator light blinking twice and then, perform the needed quantity of steps (with a maximum of 100 steps of 5 seconds)
11. If you do not need more levels, stop pressing. The indicator light will blink 3 times, 4 times and after 5 times you will leave the adjusting mode. The Perfect Time is now adjusted to the desired flow time.
12. If you need to perform steps at the adjusting level 3, wait after you see the indicator light blinking 3 times and then, perform the needed quantity of steps.

FLOW TIME ADJUSTMENT

13. To leave the adjusting mode wait until the LED blinks 4 times and then 5 times. The Perfect Time is now adjusted to the desired flow time.

14. Reassemble the rosette and the thermostatic mixing handle to the place

15. Open the water supply

Warning: In order to avoid enabling the 24 hs. hygiene flush option without intention, do not touch the piezo cap after the LED blinks 4 times.

MAINTENANCE

The Perfect Time SH 1042 has two stop valves for easy maintenance work located in the check valves and filters cover.

If you wish to stop the valves in Perfect Time SH 1042 T/TE

1. Remove the screw cover out.
2. Unscrew screw M5x8 and remove the thermostatic mixing handle.
3. Unscrew screw M5x40 and remove the rosette.

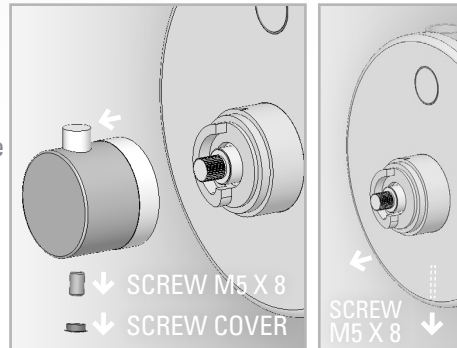

4. Now you can see two little screw heads on the check valves and filter covers. With a 3mm flat screw driver tight gently the screw located on the top of the cover.

Now the check valves do not operate.

**BE SURE TO REPEAT THIS STEP
IN BOTH SIDES**

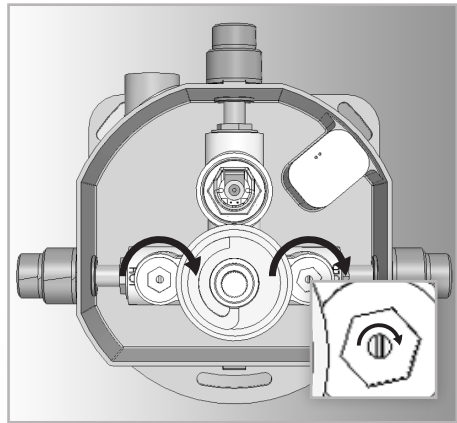

5. When the maintenance works are done, gently open the screws back.

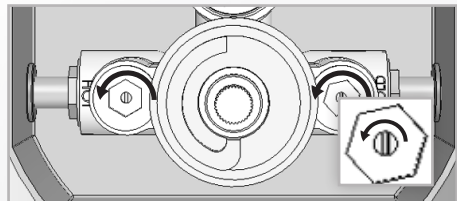

MAINTENANCE

Filters cleaning instructions for Perfect Time SH 1042 T / TE

This Perfect Time SH 1042 T/TE Shower Control is provided with a stainless steel filter preventing foreign particles to enter the lines. If the water flow has decreased, this may be because the filter is clogged. The filter can be cleaned as follows:

1. Shut-off the water
2. Remove the screw cover
3. Unscrew M5x8 and M5x40 screws from the rosette and the thermostatic mixing handle.
4. Unscrew M5x8 screws from the thermostatic mixing handle base and remove it.
5. Unscrew the covers using the 10mm Allen Key
6. Remove the check valves
7. Remove the filters and wash them under running water
8. Reassemble the filters, the check valves and screw the covers back.
9. Reassemble the thermostatic mixing handle base, rosette and finally the thermostatic mixing handle.
10. Reconnect and restore the incoming water supply
11. Make sure that there is no water leakage

Care and cleaning of chrome and special finishes

DO NOT use steel wool or cleansing agents containing alcohol, acid, abrasives, or the like. Use of any prohibited cleaning or maintenance products or substances could damage the surface of the faucet. For surface cleaning of faucet use **ONLY** soap and water, then wipe dry with clean cloth or towel. When cleaning bathroom

BATTERY REPLACEMENT

1. Close the water supply.
2. Take off the screw cover.
3. To reach access to the battery, unscrew the M5x8 using the 2.5mm Allen key provided.

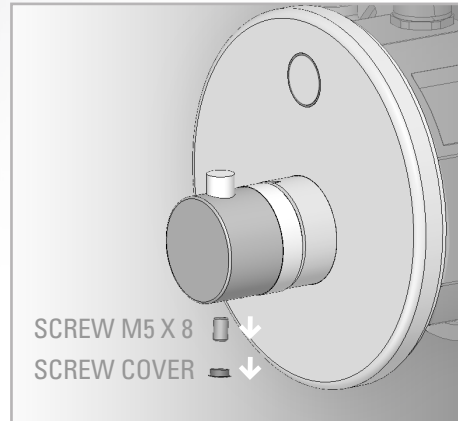

4. Unscrew the M5x40 screw and now disassemble the thermostatic mixing handle and the rosette.



5. Disconnect from the battery connector and take out the battery cover protection and remove the old battery.

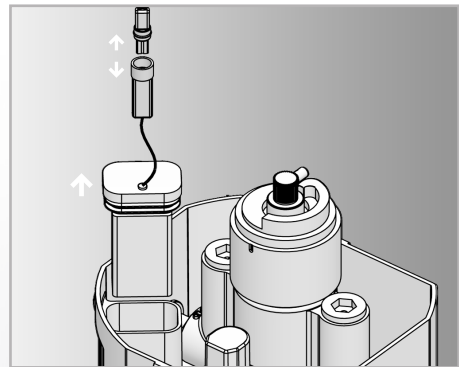

BATTERY REPLACEMENT

6. Replace the used battery with a new 9V battery. A Lithium battery is recommended.

7. Carefully place the battery inside the box and reassemble the electronic unit connector to the battery.

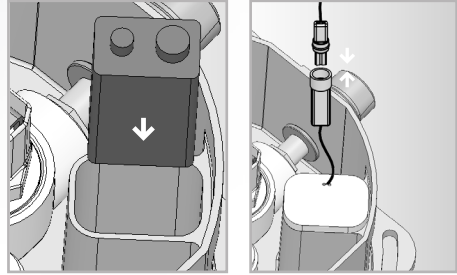

Important:

- Do not allow moisture or water into the system while the battery is being replaced.
- The interior of the shower control must be fully dry before reassembling the parts. If it not fully dry, carefully dry it.

Important: Spent batteries should not be disposed of with normal household waste. Contact your local authority for information on waste disposal and recycling.



SPARE PARTS LIST

	PERFECT TIME SH 1042 T	PERFECT TIME SH 1042 TE
Solenoid	07500065	07500065
Thermostatic Mixing Handle	07110014	07110014
Piezo button	07225176	07225176
Filter	08530014	08530014
Check valve	08520011	08520011
9 V Battery cover	06000136	06522053

SERVICE CHECK LIST

**No water is coming
out of the shower control**

Check the battery. Low or used up battery.
Replace the battery.

Check the flow time

Check the connection between the Piezo switch
connector and the solenoid connector.

Check that the battery is correctly connected.

Check the solenoid valve. If needed replace the
solenoid valve.

Use scale remover if needed. When replacing the
spring, make sure that it is in vertical position.

Check the water supply pressure. It must be 1.0-
8.0 bar (7-116 PSI). With water pressure of more
than 8 Bars, use a pressure reducing valve.

Check the flow time.

Check the solenoid valve. If needed replace the
solenoid valve.

Water flow does not stop

Water flow diminished

Check the filter's. If needed, remove it\them clean
it\them and reinstall it.

LIMITED WARRANTY

Y. Stern Engineering Ltd. warrants that its electronic faucets, flush valves and controls will be free of defects in material and workmanship during normal use for two years from the date the product is purchased.

If a defect is found in normal use, Y. Stern Engineering Ltd. will, at its discretion, repair, provide a replacement part or product, or make appropriate adjustments. Damage caused by accident, misuse, or abuse is not covered by this warranty. Improper care and cleaning will void the warranty. Proof of purchase (original sales receipt) must be provided to Stern Engineering Ltd. with all warranty claims.

Stern Engineering Ltd is not responsible for labor charges, installation, or other incidental or consequential costs other than those noted above. In no event shall the liability of Stern Engineering Ltd. exceed the purchase price of the faucet, valve or control.

If you believe that you have a warranty claim, contact your Stern Distributor, Dealer or Plumbing Contractor. Please be sure to provide all pertinent information regarding your claim, including a complete description of the problem, the product, model number, the date the product was purchased, from whom the product was purchased and the installation date. Also include your original invoice.

Y. STERN ENGINEERING AND/OR SELLER DISCLAIM ANY LIABILITY FOR SPECIAL, INCIDENTAL OR CONSEQUENTIAL DAMAGES. This warranty excludes product damage due to installation error, incorrect maintenance, wear and tear, battery, water composition, product abuse, or product misuse, whether performed by a contractor, service company, or the consumer. This warranty does not cover product damage caused by the following:

- Incorrect installation, inversions of supply pipes.
- Pressures or temperatures exceeding recommended limits.
- Improper manipulation, tampering, bad or lapsed maintenance.
- Foreign bodies, dirt or scale introduced by the water supply.

STERN

STERN ENGINEERING LTD.

15 Gan Rave Blvd., 81222 Gan Rave, Yavne, Israel

Tel: 972-8-9326000, Fax: 972-8-9326025, export@sternfaucets.com

www.sternfaucets.com



11.12 01500420